

Gated Photon Counter

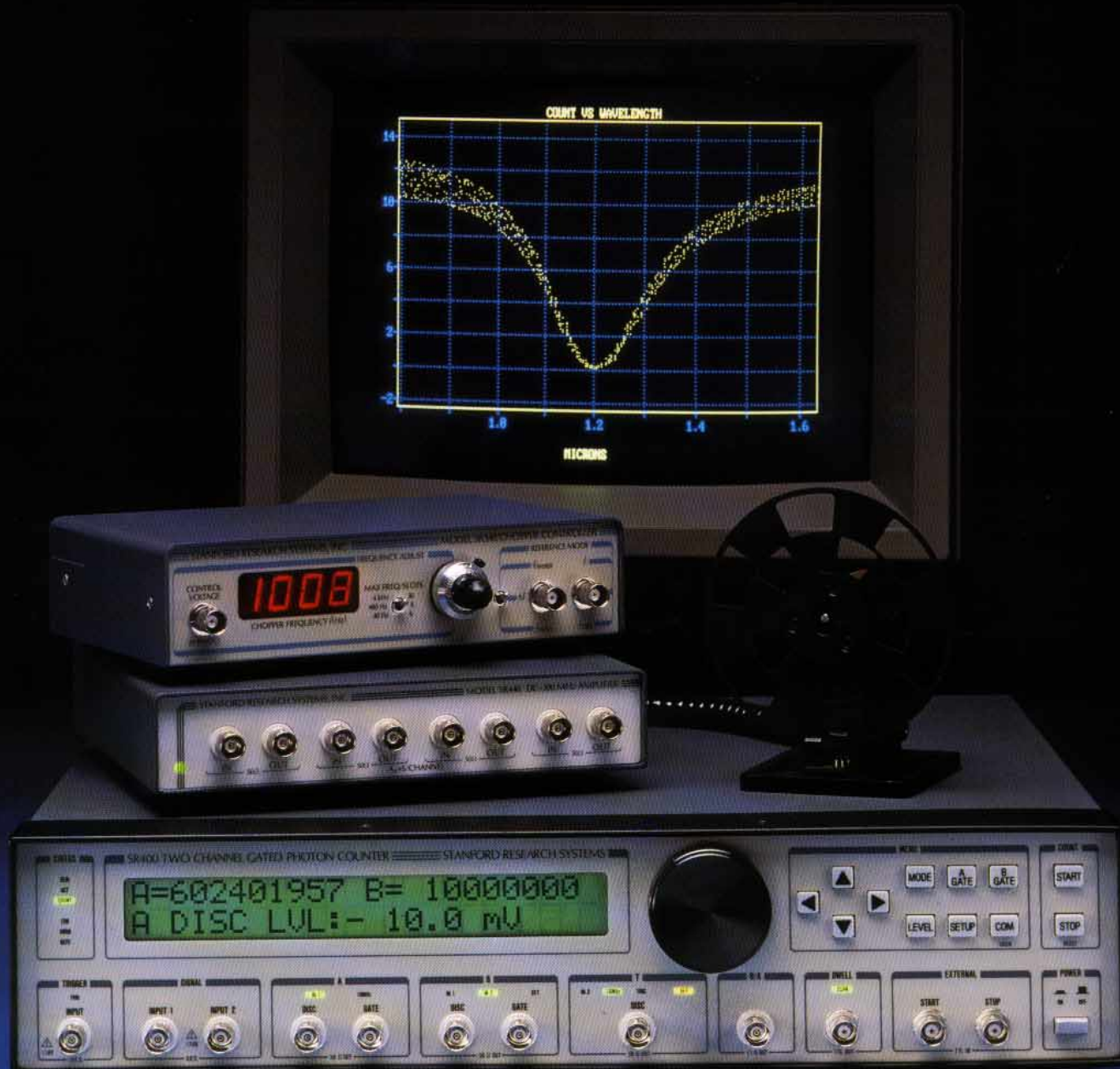

Stanford Research Systems, Inc.

Model SR400 Gated Photon Counter



A New, Integrated Approach to Photon Counting. \$5350 (U.S. List)

A New Instrument

The SR400 Photon Counter provides the fundamental advantages of photon counting without the confusion and expense of older photon counting systems. The SR400 combines amplifiers, discriminators, gate generators, coincidence gates, counters and computer control into one compact instrument.

Superior Performance

The 200 MHz performance of this instrument is unmatched at any price. An integrated, microprocessor controlled architecture permits a variety of operating modes. Drift free operation and noise discrimination offer a signal-to-noise ratio approaching the theoretical limit—capabilities which far exceed those of corresponding analog techniques.

Flexible Operation

The SR400's three counters, three discriminators, and two gate generators offer unlimited flexibility. Operating modes include boxcar, lock-in, background subtraction, source compensation, and pile-up correction modes as well as many others. The dual gate generator can narrow count intervals to 5 ns, and the gates may be scanned to measure lifetimes. Even the discriminator thresholds may be scanned to plateau photomultipliers.

Features and Performance

Discriminators and Counters

- Two 9 Digit Counters
- 200 MHz Count Rate
- Two Fast Amplifiers
- Three Scannable Discriminators
- 10 mV Sensitivity (500 μ V with the SR440 Quad Preamp)

Fast Timing

- 5 ns Pulse Pair Resolution
- Two Scanning Gate Generators
- Gate Resolution to 1 ns
- Gate and Discriminator Outputs
- Preset Time, Counts or Gates

System Features

- Powerful Operating Modes
- Lin/Log Output Voltages
- Ten Stored Set-ups
- Two Programmable D/A's
- GPIB & RS232 Interfaces
- PC Software (SR465)

Interfaces

A front panel D/A output which is proportional to the count value, or the Log of the count value, allows the instrument to be used with just a chart recorder. In addition, standard RS232 and GPIB interfaces provide complete computer control and data acquisition.

Software

A complete data acquisition and control program, the SR465, is available for use with PC compatible computers. The program provides real-time graphical displays and data reduction functions including curve fitting, smoothing and scaling. Instrument settings and data may be stored and recalled from disk, and graphs may be printed.

Applications

Photon counting offers a large dynamic range, drift free operation, and noise discrimination. These fundamental advantages may be applied to visible, UV, XUV, Auger, and mass spectroscopy—or to any experiment which must measure low photon or particle rates. The SR400 is a complete system which offers all of these advantages at an affordable price.

Applications

Boxcar Mode

This experiment uses a scanning gate to measure the lifetime of an excited state pumped by a pulsed laser. The dual gate generator is triggered by a photodiode when the laser fires. Counter A counts photons which occur during a narrow gate, while counter B counts the photons from the entire decay.

Decay data is normalized to the source intensity by counting until a preset value is reached in counter B. When B reaches its preset condition, the D/A output is set to a voltage proportional to A's count, A's gate is stepped, and a new count interval begins.

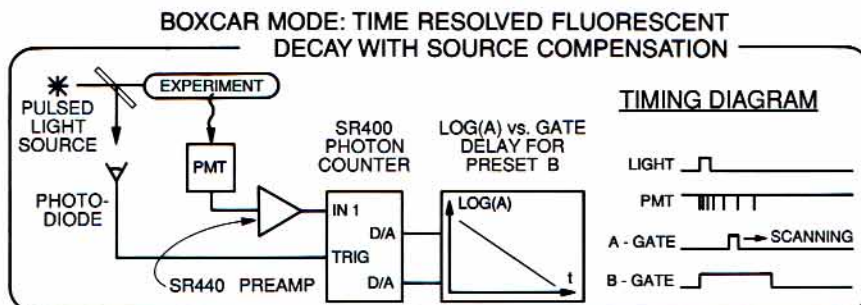

By plotting the Log of A's count value vs. A's gate delay, the exponential decay curve will be linearized and the lifetime of the excited state

may be determined from the slope on the chart recorder.

Block Diagram

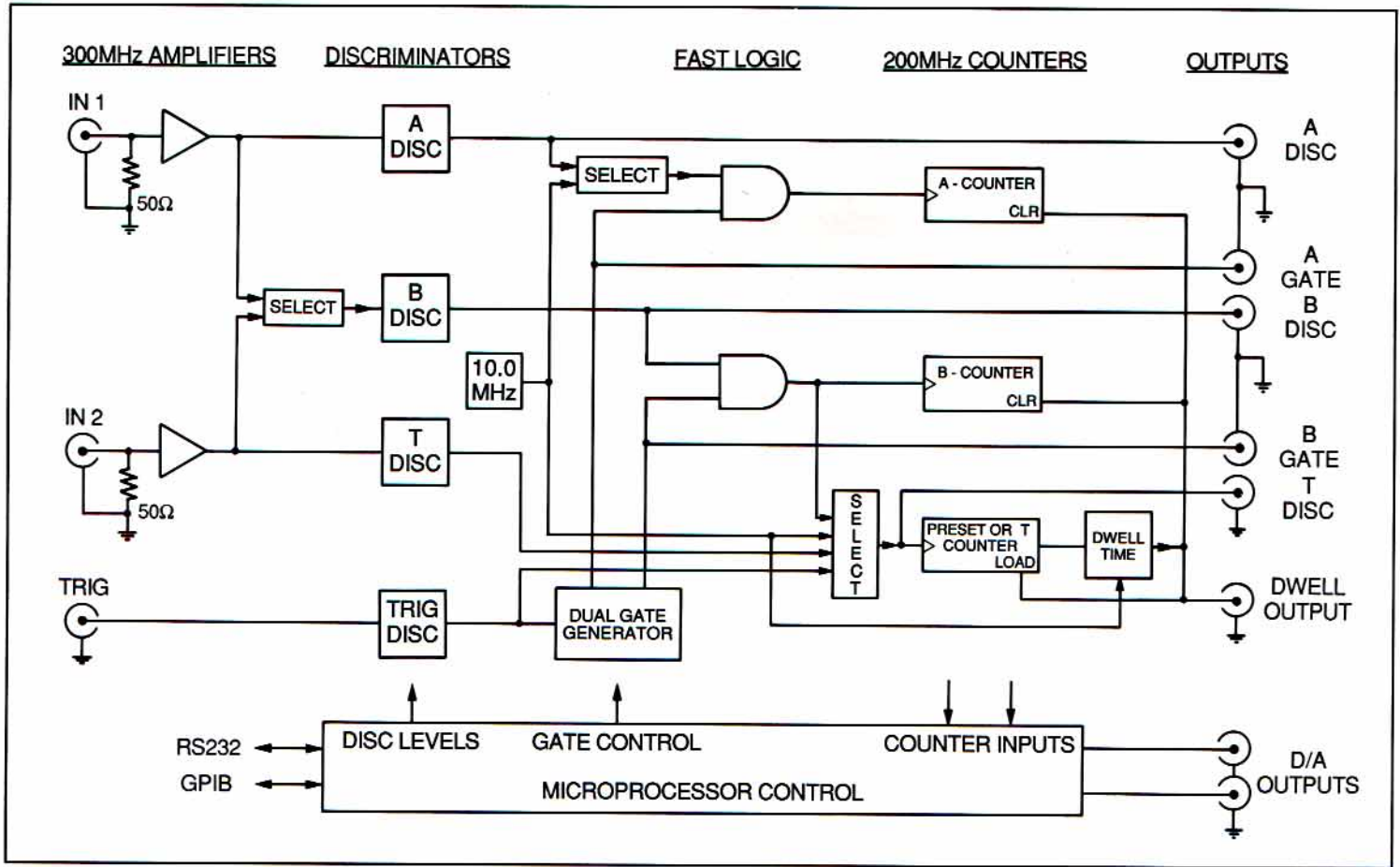

Amplifiers

The signal inputs, INPUT 1 and INPUT 2, each have a 50 Ohm, 300 MHz amplifier. These amplifiers provide high input sensitivity, fast overload recovery, and protect against transients.

Discriminators

Each amplifier has an adjustable, bipolar discriminator. An additional discriminator may be connected to either amplifier to allow 'window discrimination' or 'pile-up' correction.

Gate Generators

The trigger is detected by a high-impedance, variable-threshold discriminator. The unit

may be triggered by a TTL transition or by photodiode pulses as short as a few nano-seconds.

The trigger input starts the dual gate generator. The outputs from the gate generator enable the A and B counters. The gates can have widths from 5 ns to 1 s, may be set to a fixed delay from 25 ns to 1s, or may be scanned. The gates may also be left on continuously.

Counters

There are three 200 MHz counters. Two of the channels, A & B, are ordinarily used to count photons, while the Preset Counter is used to set the duration of the count interval. The count interval may be set to a time from 100 ns

to 25 hours, or to a number of triggers or counts from 1 to 9×10^{11} .

At the end of a counting interval, the Dwell Timer is started. The dwell time may be set from 2 ms to 1 minute. The front panel DWELL output may be used to trigger another device, such as stepping a monochromator's position.

Interface

A microprocessor system is used to control the discriminators, gate generators and counters. The processor also can communicate with another computer via the GPIB or RS232 and can output count data in an analog form via the D/A.

Lock-in Mode

Very small changes in the flux of photons may be measured by synchronous detection. An SR540 Optical Chopper is used to modulate a CW light source. The reference output from the chopper triggers the Photon Counter's dual gate generator. The A-Gate is positioned to count photons for the time that the chopper passes the light. The B-Gate is used to measure the baseline level.

The SR400 counts photons for a preset number of triggers from the chopper.

The D/A output is proportional to A-B. Since

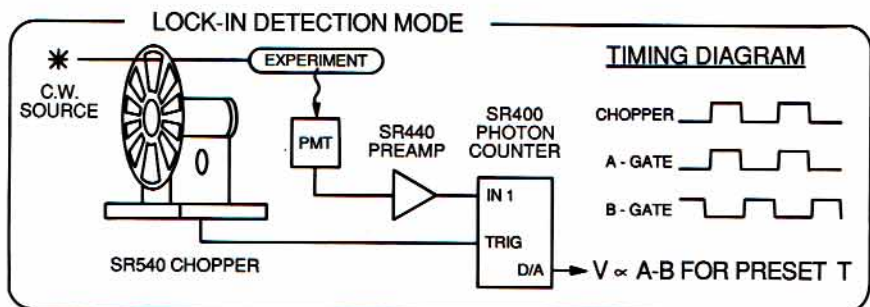

the background count is subtracted for each chopper cycle, only the signal which is syn-

chronous with the chopper will cause the output of the photon counter to change.

Software

About the Program

The SR400 Photon Counter may be used with a chart recorder or with any computer that has an RS232 or GPIB (IEEE-488) interface. For those who will use the instrument with an IBM PC/XT/AT compatible computer, the SR465 provides a complete data acquisition and analysis program.

The SR465 is a sophisticated data acquisition program written primarily in Microsoft Fortran. The program will record, display, smooth as well as store, analyze, and print graphs of the data. Graphics functions include autoscale, zoom and scroll.

Photon Counter Control

The program provides control of the Photon Counter from the computer keyboard and allows you to store and recall instrument settings from the disk. Data collection is automated and gate delays, discriminator levels, and rear panel D/A outputs are controlled.

Features

- Data Acquisition and Control
- Real Time Graphic Displays
- On-Screen Data Reduction
- Linear and Exponential Fitting
- Store and Recall from Disk
- Hardcopy Output to Printers
- HGC, CGA and EGA Support
- RS232 and GPIB
- Source Code Included

Data Reduction

Count data may be plotted against time, gate delay, or rear panel D/A voltages. On-screen cursors let you read data point-by-point, or specify a region to be integrated or fitted. Other routines allow on-line data reduction such as ratioing or exponential curve fitting. The data file format is documented to allow access by other programs.

Compatibility

The software is compatible with all major graphics adapters, including CGA, EGA, HGC and AT&T PC-6300. Both RS232 (COM1 or COM2) and GPIB (National Instruments or C.E.C) interfaces are supported.

Control Program Examples

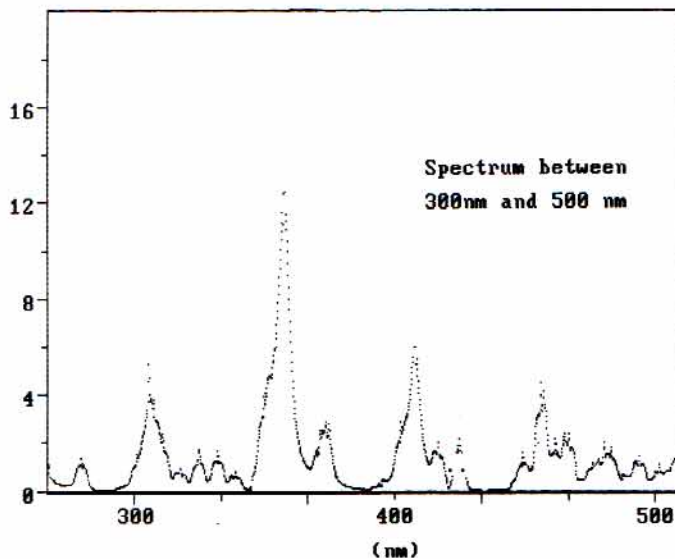

The program reads and displays count data, advances the spectrometer's position, and starts a new count interval.

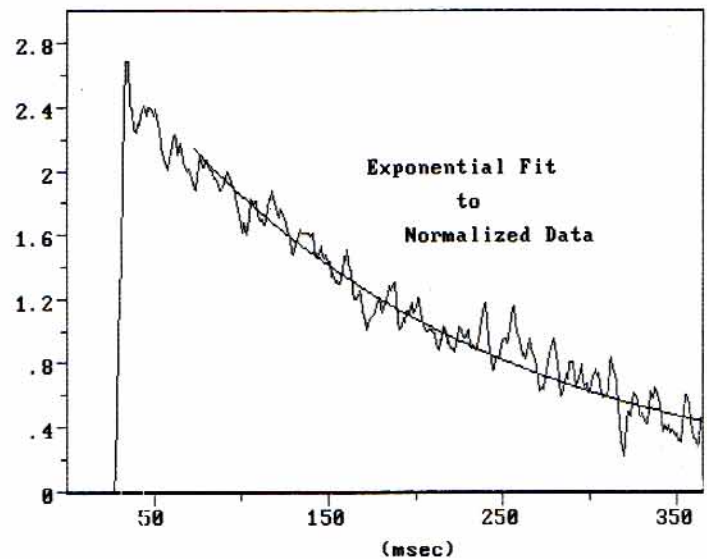

The program fits an exponential to count data from the Boxcar Mode application.

Accessories

SR445 Quad Preamp

The SR445 Quad Preamplifier has four high speed, 50 Ohm amplifiers. The channels have a fixed gain of 5.0 and they may be cascaded for an overall gain of up to 125.

The SR445 allows a 500 μ V PMT signal to be counted by the SR400 Photon counter. Noise pickup is reduced by placing the pre-amplifier close to the phototube.

Gain: 5.0 typical per channel
Bandwidth: dc to 300 MHz (3dB pt.)
Rise/Fall: 1.2 ns
Input Range: \pm 250 mV

Noise: 50 μ V rms
Recovery: < 4 ns for 20 x overload
Protection: \pm 3.5 Vdc, \pm 50 Vdc pulse
Power: 16 W, 100 / 120 / 220 / 240 Vac

SR540 Optical Chopper

The SR540 Optical Chopper permits synchronous detection of optically induced signals when used with photon counters or lock-in amplifiers. The unit can chop light at 4 Hz to 4 KHz as set by a ten turn potentiometer or control voltage input. A four digit LED display shows the chopping frequency. Two

blades are included.

Chop Rate: 4 Hz to 4 KHz
Phase Jitter: 0.2 deg rms, 50-400 Hz
0.5 deg rms, 400-4000 Hz

Display: 4 digit, 1 Hz accuracy
References: TTL outputs for both rows of slots as well as sum and difference frequencies.

Blade Dia: 4.00"
Chopper Head: 2.8" x 2.1" x 1.0". 6' cord
Controller: 7.7" x 5.1" x 1.8"
Power: 12 W, 100 / 120 / 220 / 240 Vac

Specifications

Overview

There are three counters identified as A, B, and T. The counters can count to 200 MHz.

Counter A can count INPUT 1 or the 10 MHz internal clock. Counter A is gated by A-Gate, and has a count capacity of 10^9 .

Counter B can count INPUT 1 or INPUT 2. Counter B is gated by B-Gate, has a count capacity of 10^9 and may be used as the preset counter to determine the count interval.

The Preset Counter (T) can count the internal 10 MHz clock, INPUT 2 or the trigger input. This counter may be preset to determine the count period for up to 25 hours or 9×10^{11} counts, gates or triggers. The timer has an accuracy of 25 ppm from 0 to 50°C.

Trigger Input

Impedance: 10 KOhm
Threshold: ± 2.000 Vdc in 1 mV steps
Slope: Rising or falling edge
Protection: 15 Vdc, 100 V for 1 μ s

Gate Generators

There are two independent gates, A-Gate and B-Gate, which enable the A and B counters. Both gates are triggered by the TRIGGER input. The gates may be fixed in time or scanned. The GATE output shows the position of the gate with respect to the discriminator outputs.

Insertion delay: 25 ns
Maximum delay: 999 ms
Minimum gate width: 5 ns
Maximum gate width: 999 ms or CW
Resolution: 0.1%, 1 ns minimum
Accuracy: 2 ns + 1%
Jitter: 200 ps rms + 100 ppm
Maximum trigger rate: 1 MHz
GATE view output: NIM levels into 50 Ohms
GATE view error: < 2 ns

Amplifier Inputs (INPUT 1 & 2)

Bandwidth: dc to 300 MHz
Input Impedance: 50 Ohms
Linear Range: ± 300 mV (at input)
Input Protection: ± 5 Vdc, 50 v for 1 μ s
Overload Recovery: 5 ns

Computer Interface

GPIB (IEEE-488) and RS232 (up to 19.2 Kbaud) provide full instrument control and data transmission. Data may be transmitted from the 2000 point buffer point-by-point, continuously, or at the end of a scan.

General

Rack Mount: Included (standard 19" rack)
Dimensions: 16" x 13" x 3.5"
Weight: 10 lbs
Power: 35 Watts 100/120/220/240 Vac
Warranty: One year parts and labor on materials and workmanship.

Discriminators

Each input has its own discriminator for counting signal inputs. Each discriminator may be set to a fixed level or scanned. A rear panel input (TTL active high) can inhibit the discriminators to stop the count.

Discriminator range: -300 mV to +300 mV
Discriminator slope: Rising or Falling
Disc. resolution: 0.2 mV
Input offset voltage: < 1 mV
Minimum pulse input: 10 mV (50 μ V w/ SR440)
Pulse pair resolution: 5 ns
DISC outputs: NIM levels into 50 Ohms

Operating Modes

A & B, A+B or A-B for preset time, triggers, gates or counts. These counting modes, together with three independent discriminators and two gate generators, allow operation in the dual counter, lock-in, boxcar, ratio (for source compensation), reciprocal (for constant statistics), background subtraction, windowing (for pulse height analysis) and pile-up correction modes of operation.

Scan and Dwell

The number of count periods (data points) in a scan may be set from 1 to 2000. The duration of one count period is determined by the preset condition (i.e., a preset number of counts, triggers or time.)

The time between consecutive count periods, the DWELL time, may be set from 2 ms to 60 s. The DWELL output will be TTL high during the DWELL time. This output can be used to trigger devices such as stepper motors.

The START and STOP keys (and front panel, active high, TTL inputs) are used to start, pause and stop scans. At the end of a scan (of 1 to 2000 count periods) the unit may be programmed to stop or repeat the scan.

Count data for one scan is queued in a buffer memory for transmission to a computer during or after a scan.

Display Mode

Continuous: Displays current counter value.
Hold: Displays final count value.

D/A Outputs

The front panel D/A Output is proportional to A, B, A-B or A+B, depending upon the count mode selected. The D/A value is updated at the end of each count period. The output has logarithmic scaling (1 V/decade) or linear scaling (using three decades).

There are two rear panel D/A outputs. These outputs may be set or scanned from the front panel or via the computer interface. These outputs are available to drive chart recorders, or to control analog devices in the experiment.

Full Scale: ± 10 Vdc
Resolution: 12 bits (5 mV)
Current Rating: 10 mA
Output Impedance: < 1 Ohm
Accuracy: 0.1% + 5mV

Abridged Command List

Mode

CM j	Count mode: A&B, A-B, A+B, (for preset value in T counter) or A for preset B.
CI i,j	Counter i's source: 10 MHz, IN 1, IN 2, TRIG.
CP i,n	Preset counter i to $1 \leq n \leq 9E11$.
NP m	Scan length set to m periods.
NN	Read current scan position.
NE j	Set end of scan mode to repeat or stop.
DT t	Set DWELL time.
AS j	Front D/A to A, B, A-B, A+B.
AM j	Front D/A to Log or linear.
SD j	Set Display mode continuous or hold.

Levels

TS j	TRIG Slope to rise or fall
TL v	TRIG Level to $-2.000 \leq v \leq 2.000$
DS i,j	DISC i Slope to rise or fall.
DM i,j	DISC i to fixed or scan.
DY i,v	DISC i scan step to $-0.0200 \leq v \leq 0.0200$ V.
DL i,v	DISC i level to $-0.3000 \leq v \leq 0.3000$ V.
DZ i	Read current DISC i level (during scan).
XM i,j	Ith D/A set to fixed or scan.
XY i,v	Ith D/A scan step to $-0.500 \leq v \leq 0.500$ V.
XL i,v	Ith D/A level to $-10.000 \leq v \leq 10.000$ V.
XZ i	Read rear D/A level during a scan.

Gates

GM i,j	Gate i to CW, fixed or scan.
GY i,t	Gate i delay step size from 0 to 99.92 ms.
GD i,t	Gate i delay from 0 to 999.2 ms.
GZ i	Read Gate i delay position during a scan.
GW i,t	Gate i width from 5 ns to 999.2 ms.

Data

QA	Read last count in counter A.
QB	Read last count in counter B.
QA m	Read point m from scan buffer for counter A.
QB m	Read point m from scan buffer for counter B.
EA	Send counter A buffer.
EB	Send counter B buffer.
ET	Send counter A and B buffer.
FA	Start scan and send data for counter A.
FB	Start scan and send data for counter B.
FT	Start scan and send data from both counters.
XA	Read current contents of counter A.
XB	Read current contents of counter B.

Front Panel

CS	Count start (same as START key).
CH	Count pause (same as STOP key while counting).
CR	Count reset (same as STOP key pressed twice).
CK j	Simulate key press j.
RR	Rotate knob right (CW or up) 1 step.
RL	Rotate knob left (CCW or down) 1 step.
SC	Read cursor position: Left, right or inactive.
MI j	Front panel to local, remote, or locked-out.
MS str	Display string on menu line.
MS	Return menu line to normal display.
MD j,k	Display line k of menu j.
MM	Read menu number of display (j)
ML	Read menu line of display (k)

Store and Recall

ST m	Store instrument settings to location m.
RC m	Recall instrument settings from location m.
RC 0	Recall default settings.

Interface

CL	Clear instrument.
SV m	GPIB SRQ mask to $0 \leq m \leq 255$.
SS	Read status byte.
SS j	Read bit j (0-7) of status byte.
SI	Read secondary status byte.
SI j	Read bit j (0-2) of secondary status byte.
SW m	RS232 character wait interval to $m * 3.33$ ms
SE j,k,l,m	ASCII codes for RS232 terminator sequence.
SE	Clear RS232 terminator sequence to defaults.

In general, if a parameter is omitted from a command, then the current value of that parameter will be returned. For example, the command "TL 1.5" sets the trigger level to 1.5 Vdc, while the command "TL" will cause the instrument to return "1.5".



Ordering Information (US List)

SR 400 Photon Counter	\$5350
SR445 Quad 300 MHz Preamp	\$1100
SR540 Optical Chopper	\$1095

All specifications and prices subject to change (01/03)



Stanford Research Systems, Inc.

1290D Reamwood Avenue, Sunnyvale, California 94089, (408) 744-9040, FAX 4087449049

email: info@thinkSRS.com www.thinkSRS.com